

# Reddy®

'92-'95 Honda Civic  
TD04H-15G Turbo Kit  
1.6 l VTEC  
*M/C version*



## HONDA CIVIC TD-04H TYPE-1 TURBO KIT

### PARTS LIST

1. TD-04 H 15G 3.5cm <sup>2</sup>	1
2. Exhaust Manifold	1
3. Turbo Outlet Adapter	1
4. Down Pipe 50Ø Steel Pipe	1
5. Air Intake Pipe A-1 60Ø Steel Pipe	1
6. Charge Pipe C-1 60Ø Steel Pipe	1
7. Charge Pipe C-2 60Ø Steel Pipe	1
8. Charge Pipe C-3 60Ø Steel Pipe	1
9. Breather Hose 10mm X 400mm	1
10. Oil Pressure Hose 800mm SUS	1
11. Oil Pressure Hose Banjo Union, Small Male / Female 10 X 1.24 mm	1
12. Oil Pressure Hose Copper Gasket Small	2
13. Oil Pressure Hose 3 Way T 1/8 NPT	1
14. Oil Pressure Hose Straight Union 1/8NPT	3
15. Oil Return Flange Tube (Universal Type 15mm) Turbo Side	1
16. Oil Return Flange Tube (Universal Type 15mm) Oil Pan Side	1
17. Oil Return Hose 19mm X 300mm	1
18. Oil Return Hose Band 19mm	2
19. Oil Return Flange Gasket	2
20. Hose 50Ø X 70mm	1
21. Hose 60Ø X 70mm	5
22. Hose Band 50Ø Clamp #32	2
23. Hose Band 60Ø Clamp #36	10
24. Hose Band 10Ø Clamp #5	2
25. 8 mm to 8mm Hose Union	1
26. Turbine Gasket In	1
27. Turbine Gasket Out	1
28. Muffler adapter Gasket	1
29. Heat shield	1
30. Thermo Wrap 100mm X 1000mm	1
31. Zip Ties 200mm	10
32. Air Filter	1
33. Air Filter Adapter 60mm	1
34. 6m X 15mm p=1.0 Stainless B. S/W. F/W. N (Oil Return~Oil Pan)	2
35. 10m X 45mm p=1.25 Steel Cap B. S/W. N (Down Pipe)	3
36. 8m X 30mm p=1.25 Stainless Stud B. S/W. F/W. N (Exhaust Manifold -Turbo)	4
37. 8m X 35mm p=1.25 Stainless Stud B. S/W. F/W. N (Muffler adapter - Turbo)	3
38. 8m X 35mm p=1.25 Stainless B. S/W. F/W. (Exhaust Manifold -Turbo)	3
39. 8m X 70mm p=1.25 Stainless B. S/W. F/W. (Exhaust Manifold -Turbo)	1
40. 8m X 15mm p=1.25 Stainless B. S/W. F/W. (Exhaust Manifold -Turbo)	4
41. 8m p=1.25 Stainless S/W. F/W. N (Cylinder Head)	9
42. 6m X 15mm p=1.0 Stainless B. S/W. (Turbine Oil Return)	2
43. FCU Fuel Control Unit w/Harness and connectors	1

# Honda Civic Turbo Kit Parts List

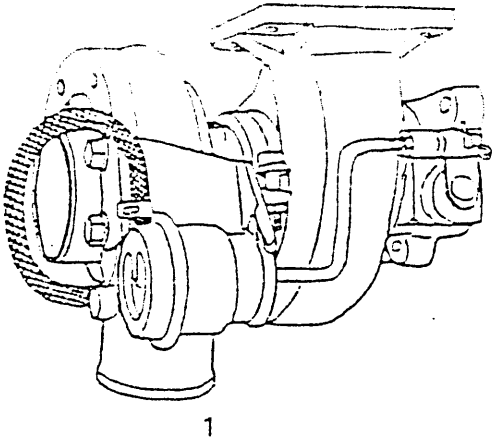

1

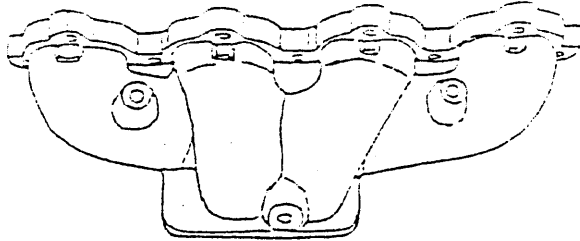

2

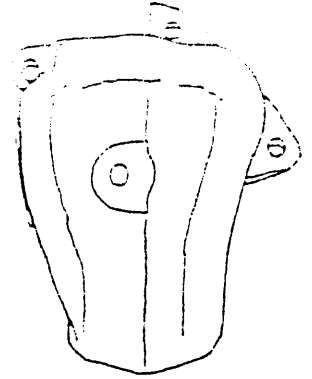

3



4

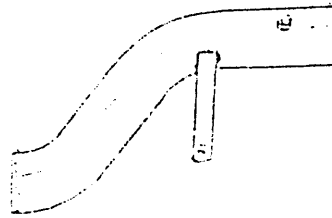

5

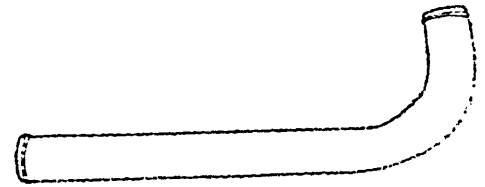

6

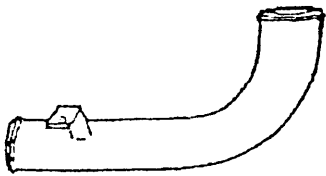

7

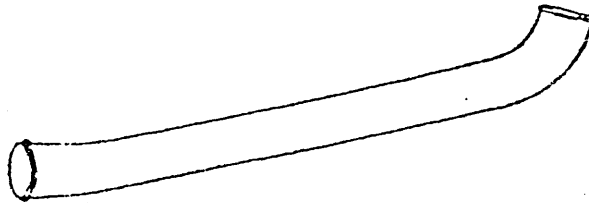

8

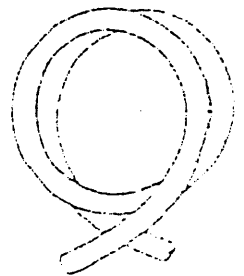

9

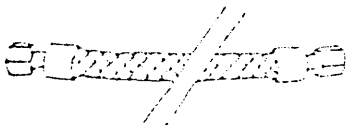

10



11



12



13



14



15



16

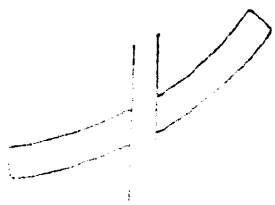

17



18



19

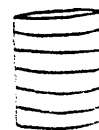

20



21



22



23



24

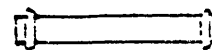

25

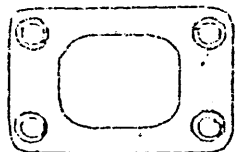

26

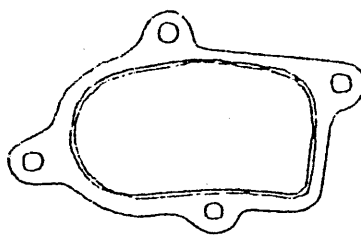

27

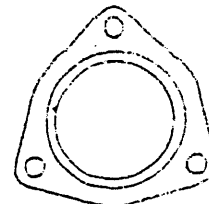

28

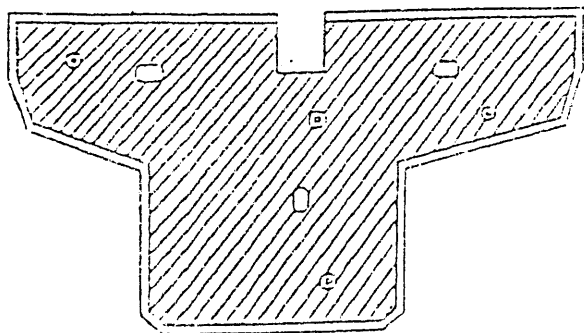

29



30

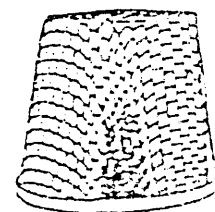

32

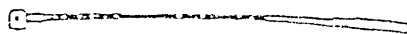

31



33

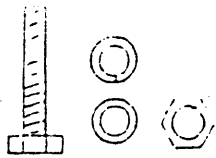

34

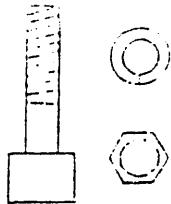

35

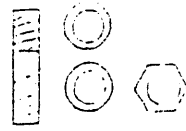

36

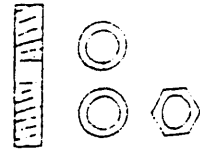

37

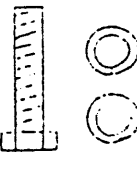

38

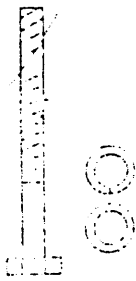

39

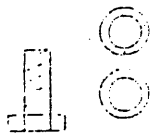

40



41

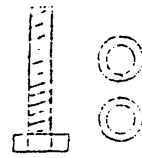

42

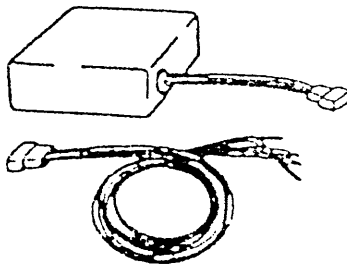

43

### 3 TURBO KIT INSTALLATION

\* Always disconnect the battery negative cable from the battery negative terminal before working on any part of the vehicle.

#### 3-1 STOCK PARTS REMOVAL

- (1) Unplug the O<sub>2</sub> sensor and take the exhaust manifold cover from the exhaust manifold. Then, remove the O<sub>2</sub> sensor.
- (2) Remove the exhaust manifold by removing the nine 8 mm nuts. Inspect the ex. manifold gasket for any damages, replacing the gasket with a new one is recommended.
- (3) Remove the stock air filter box, and air intake duct.

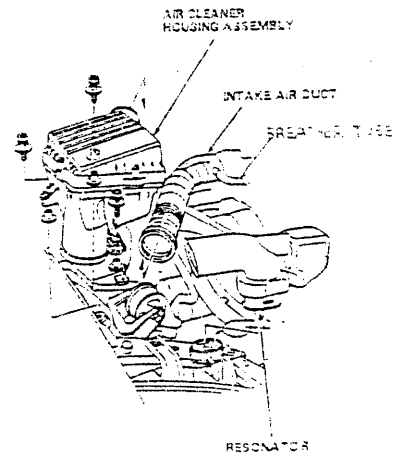
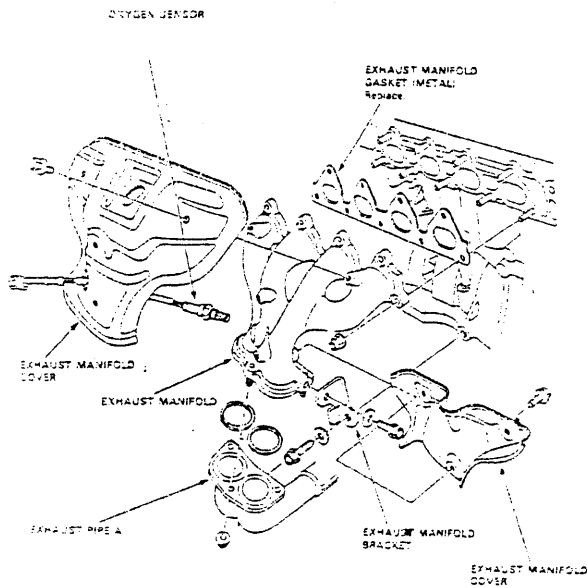

### 3-2 TURBO KIT INSTALLATION

- (1) Install the oil return pipe with gasket, and oil pressure banjo union fitting to the TD-04 turbo charger.
- (2) Install the turbo outlet adapter to the TD-04 Turbo using the turbo outside gasket.
- (3) Install the TD-04H Turbo Assy to the exhaust manifold using the turbo gasket.
- (4) Install ex. manifold to the cylinder head using the stock Ex. Manifold gasket.

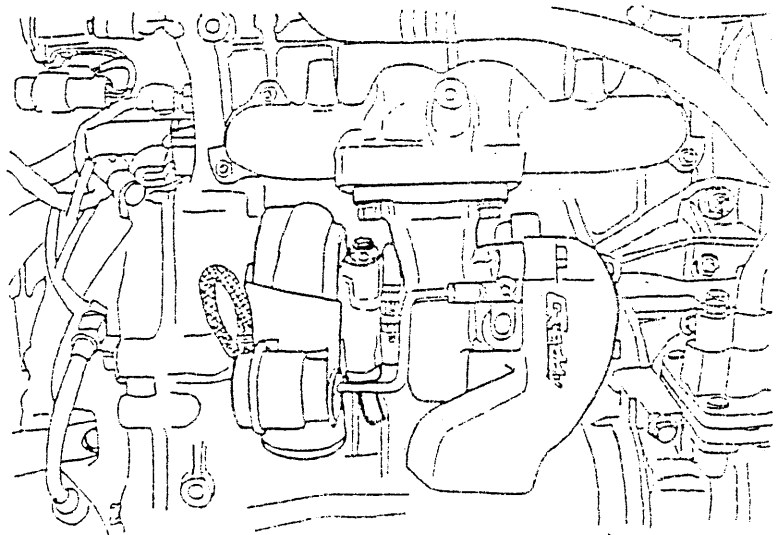
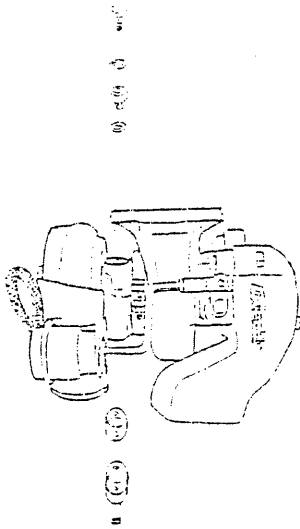

(5) Disconnect and remove the oil pressure sensor. Connect the oil pressure hose between cylinder Block and the turbo oil inlet. Oil pressure line should be connected to the oil pressure sensor unit using the T union at the cylinder Block. ( The oil pressure sensor can easily be reached with the oil filter removed. ) Oil pressure union is 1/8 PT. Reconnect the oil pressure sensor. Connect the other end of the oil pressure hose to the banjo fitting on the turbo you have installed in step (2). Route the oil pressure hose over the right side of the valve cover by the timing belt.

( Parts # 9, 12, 13 )

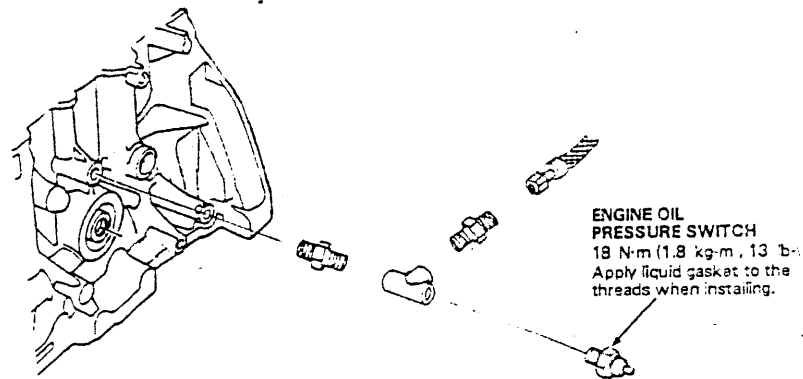

(6) Drain the oil and remove the oil pan, and drill two 8 mm hole for bolts and one 15 mm hole for oil return ( See the following illustration. Units in millimeter ). Bolt the gasket and oil return flange tube at a hole on the oil pan. Before installing the oil pan, inspect the gasket, and clean the inside of the oil pan. It is recommended to cut off the flange of the return pipe and weld the oil return pipe to the oil pan.

\*The oil pan needs to be in the perfect condition without bumps and dings to avoid oil leaks from the oil return flange gasket.

\*When drilling use the gasket as a template.

\*Try to drill as clean as possible using a good drill bit.

\* It is recommended to weld on the return pipe, for those of you that has a welder, cut off the flange from the return pipe. When welding the return pipe on, first spot weld the pipe to the pan, and make sure the angle of the pipe is adequate, by test fitting the pan back on the block. Check the clearance. Then weld the flange completely.

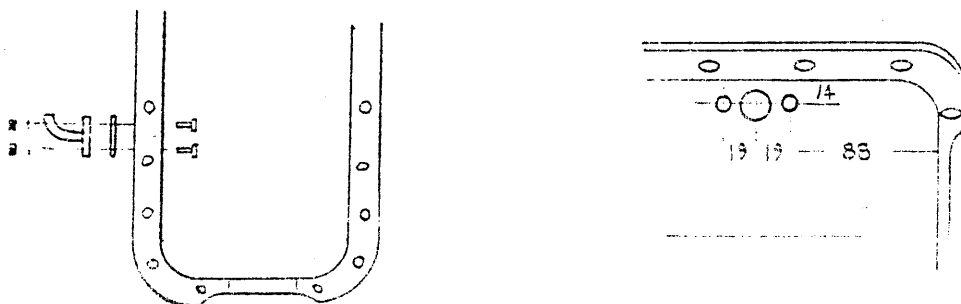



- (7) Cut the oil return hose to a proper length, and wrap the hose with thermo wrap. Connect the turbo oil return tube to the oil pan with the hose.
- (8) Install the O2 sensor to the down pipe, and install the down pipe.
- (9) Install the charge pipe C-1 to the Turbo with 50Ø hose and hose bands.

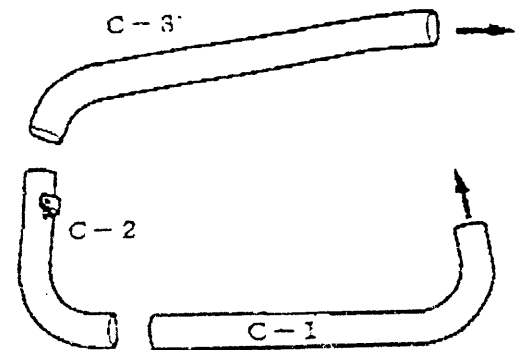
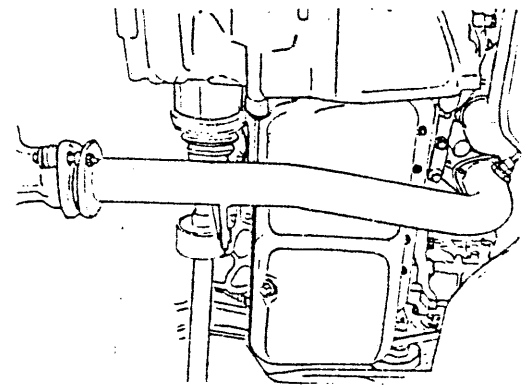

Install the charge pipe C-2 to C-1 as shown.

Secure C-2 to the body as shown.



Install the charger pipe C-3 to the throttle body and C-2 coming out from the RH front fender.

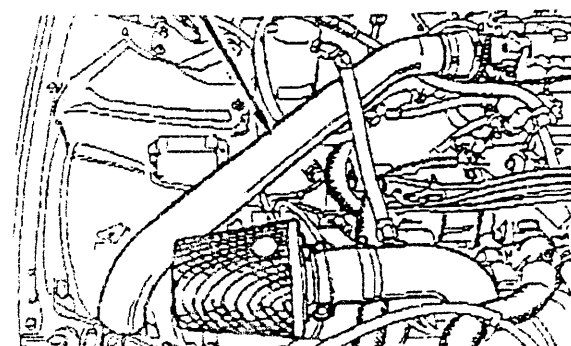

(7) Cut the oil return hose to a proper length, and wrap the hose with thermo wrap. Connect the turbo oil return tube to the oil pan with the hose.

(8) Install the O2 sensor to the down pipe, and install the down pipe.

(9) Install the charge pipe C-1 to the Turbo with 50Ø hose and hose bands.

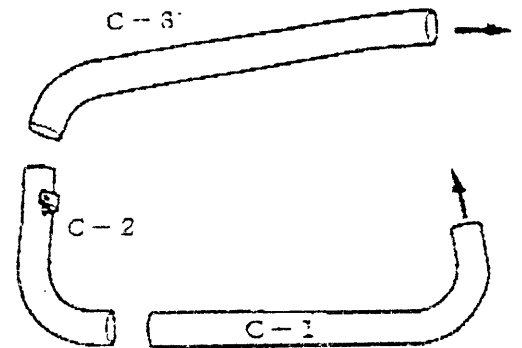
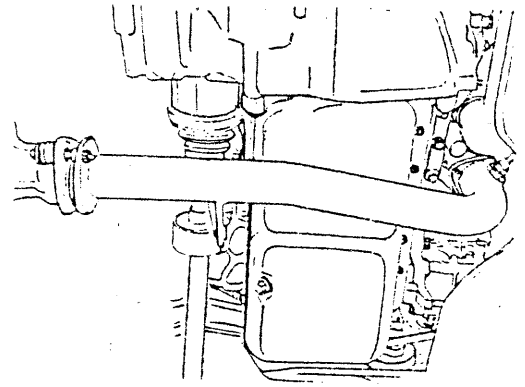

Install the charge pipe C-2 to C-1 as shown.

Secure C-2 to the body as shown.

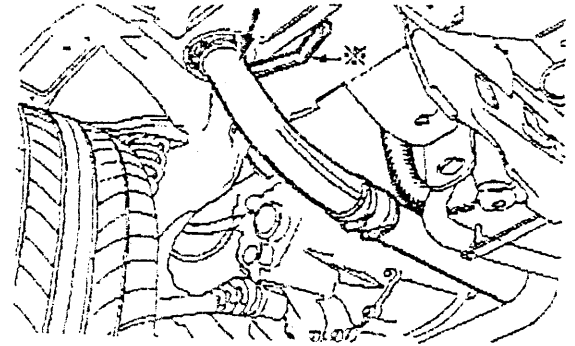

Install the charger pipe C-3 to the throttle body and C-2 coming out from the RH front fender.

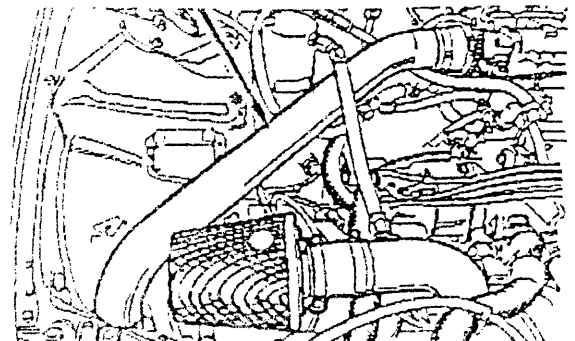

## FCU Installation

- (1) Disconnect the negative terminal of the battery.
- (2) Take out the Factory ECU.
- (3) Connect the FCU to the factory ECU as shown in the diagram below.

\* Make sure that all connection in soldered together. If a crimp connector is used, it might cause a check engine light to come on.

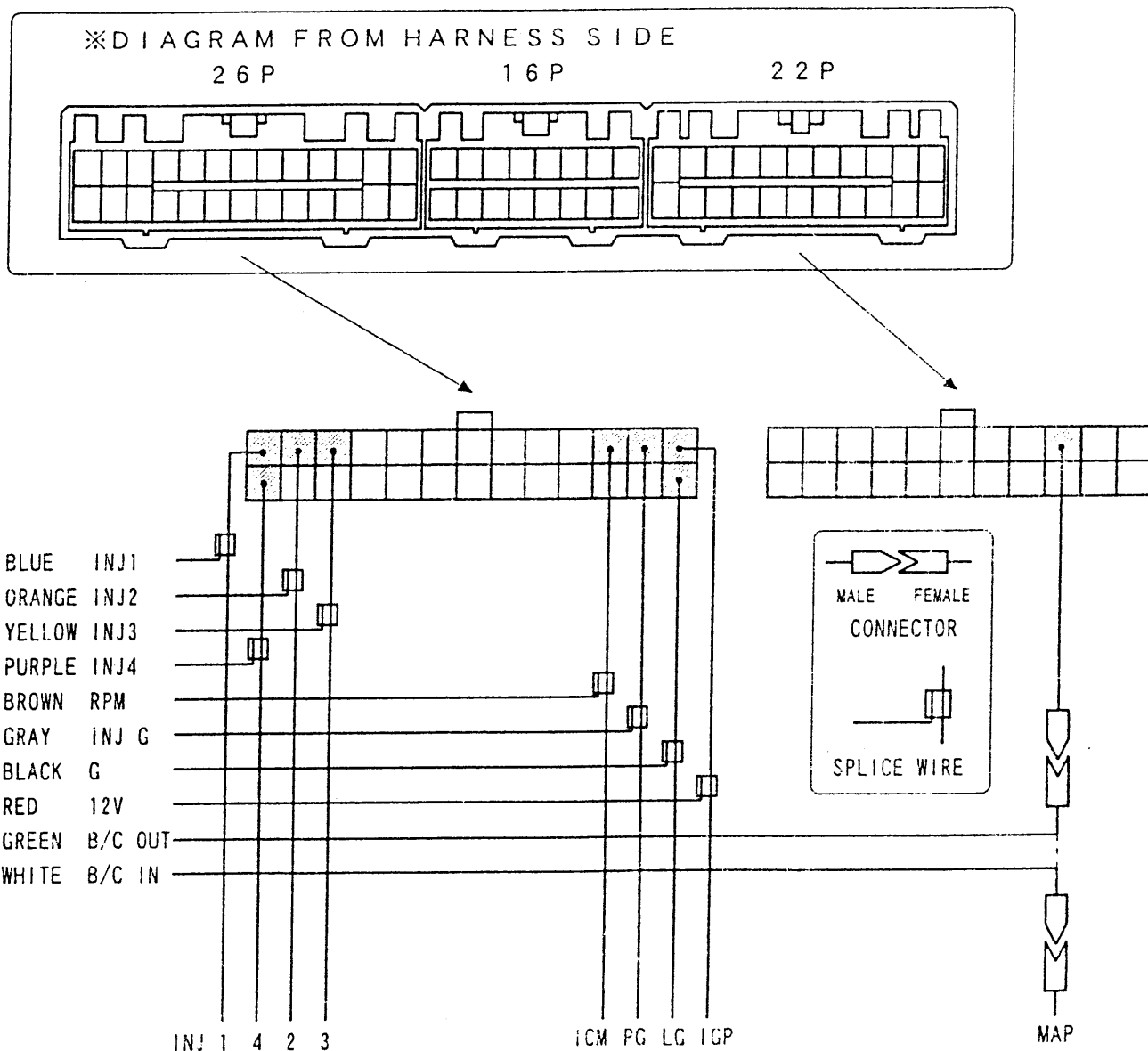

### Factory ECU

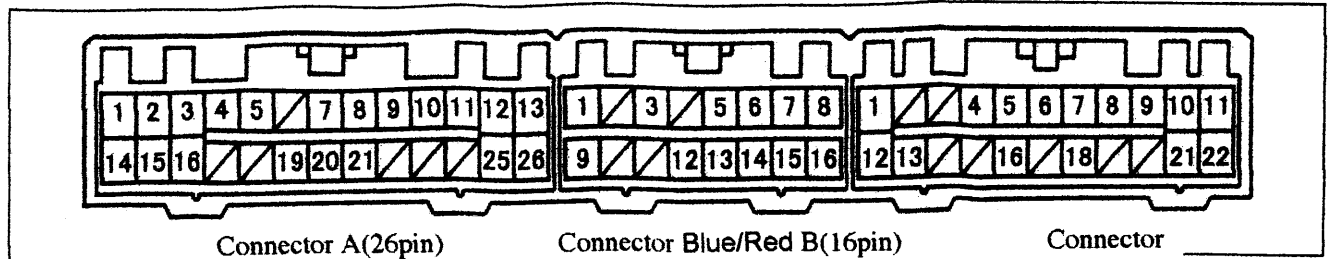

※ Looking from harness side

### e-manage Diagram

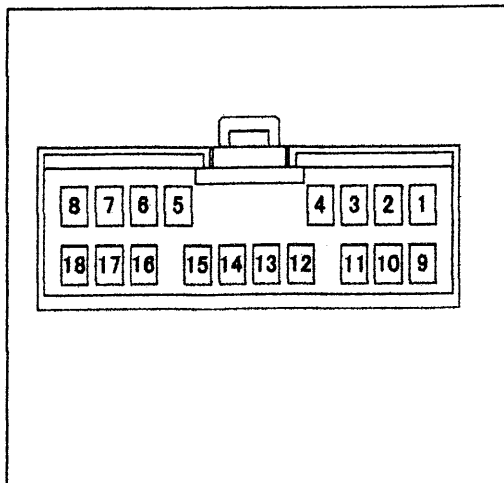
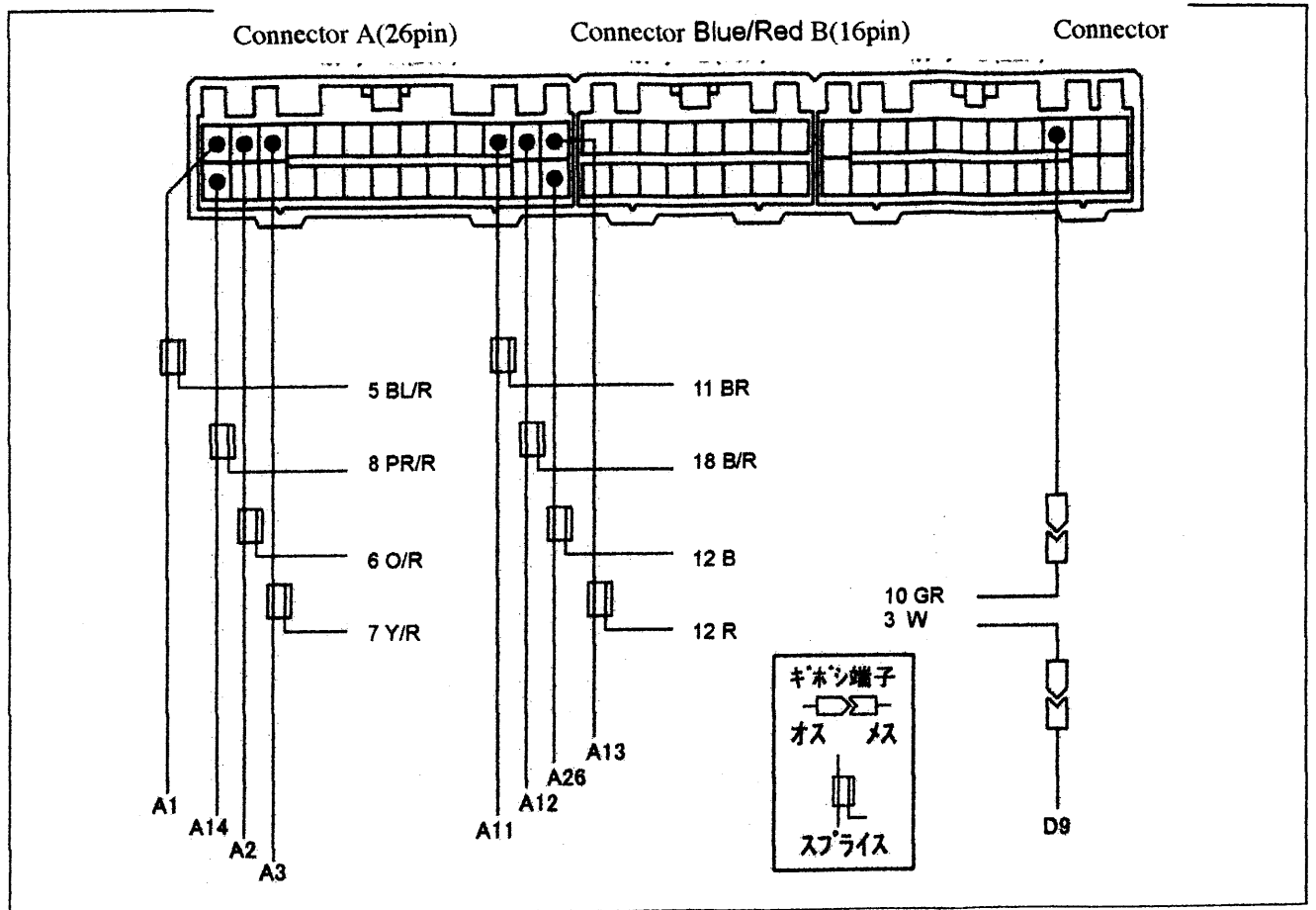

e_m a n a g e			E C U	
Pin #	Color	Signal	ECU PIN	Description
3	White	Map in	D_9	MAP (Harness)
5	Blue/Red	I N J 1	A_1	I N J 1
6	Orange/Red	I N J 2	A_2	I N J 2
7	Yellow/Red	I N J 3	A_3	I N J 3
8	Purple/Red	I N J 4	A_14	I N J 4
10	Green	Map out	D_9	MAP (ECU)
11	Brown	R P M	A_11	I G P
12	Black	G N D	A_26	L G
13	Red	I G +1 2 V	A_13	I G P 1
18	Black/Red	I N J Ground	A_12	P G

## Before starting the Engine

- Re-install the oil filter you removed, and add engine oil.
- Remove the ECU fuse located next to the battery, and crank the engine by turning the ignition key to get oil pressure in the turbocharger.
- Reconnect the battery.
- Insert the ECU fuse back, and you are ready to start the engine.

## Precautions

- Max. boost pressure setting: 0.35 kg/cm or 5 psi
- Actuator is factory set and sealed, tampering the actuator will cause engine damage
- It is highly recommended to monitor the boost pressure and Exhaust temp with GReddy gauge.
  - After starting the engine check for fuel, air, and oil leaks.
  - The use of premium fuel will be necessary ( 92 octaine or higher ).

## Important!

- This turbocharger kit is designed to boost only **0.35 kg/cm<sup>2</sup> (5 psi)**
- Please check the boost level on the vehicle with an accurate boost gauge before taking it out on any public highways.
- This kit can be modified to boost more, for off-road/race only situations. For more information please contact your *Authorized GReddy Dealer*.